

ESCOLA BÁSICA E
SECUNDÁRIA DE SÃO ROQUE DO PICO

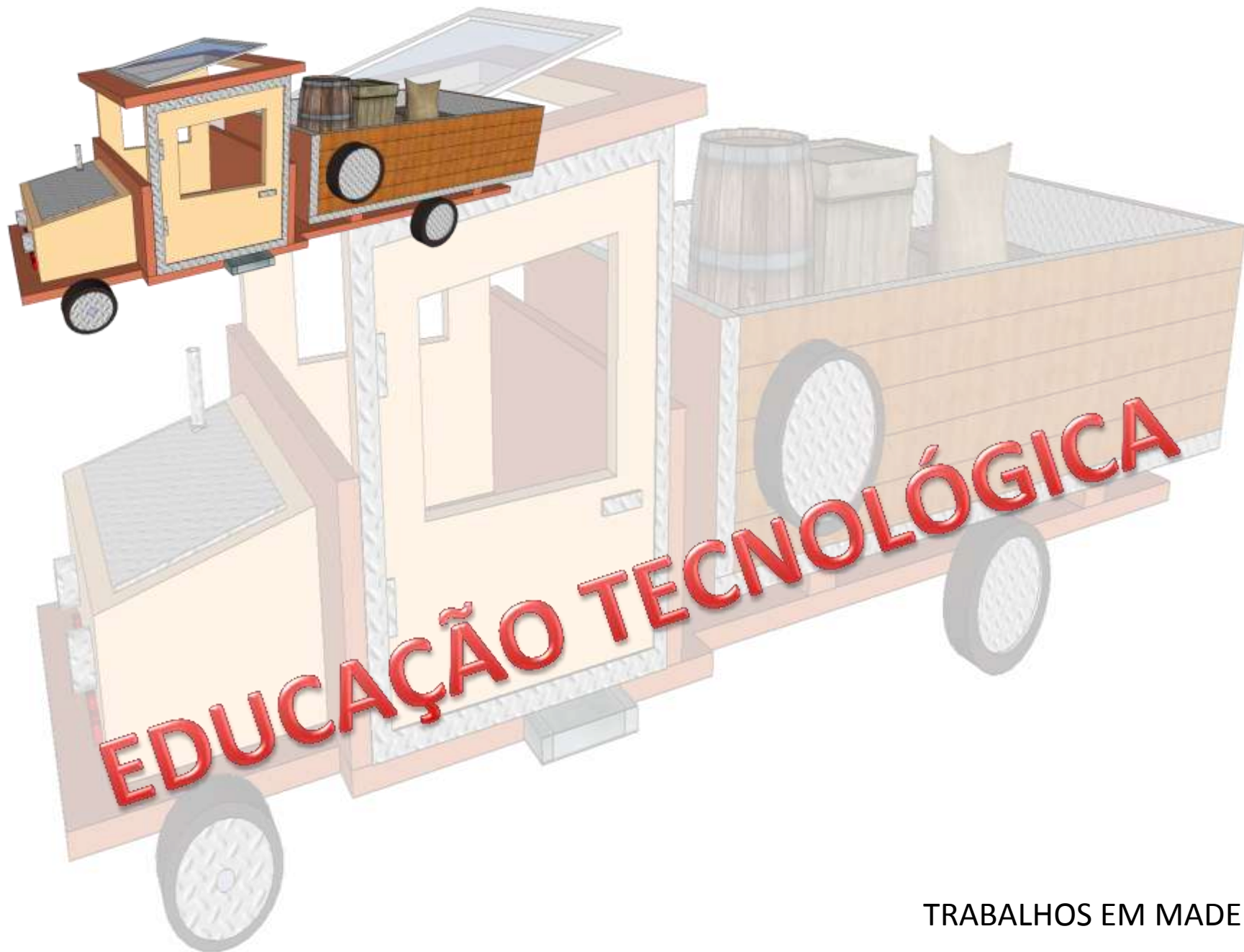

EDUCAÇÃO TECNOLÓGICA

TRABALHOS EM MADEIRA

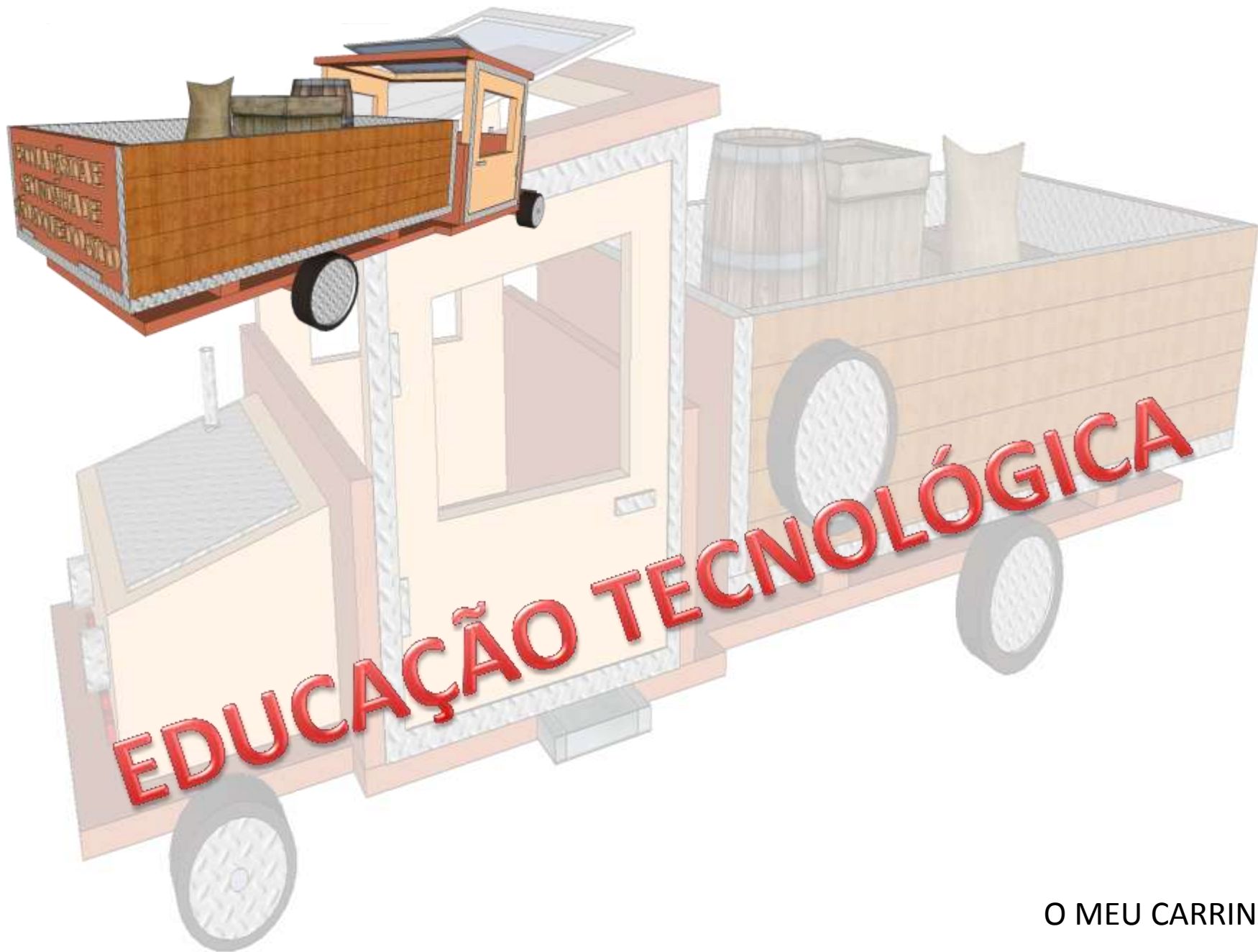

EDUCAÇÃO TECNOLÓGICA

O MEU CARRINHO

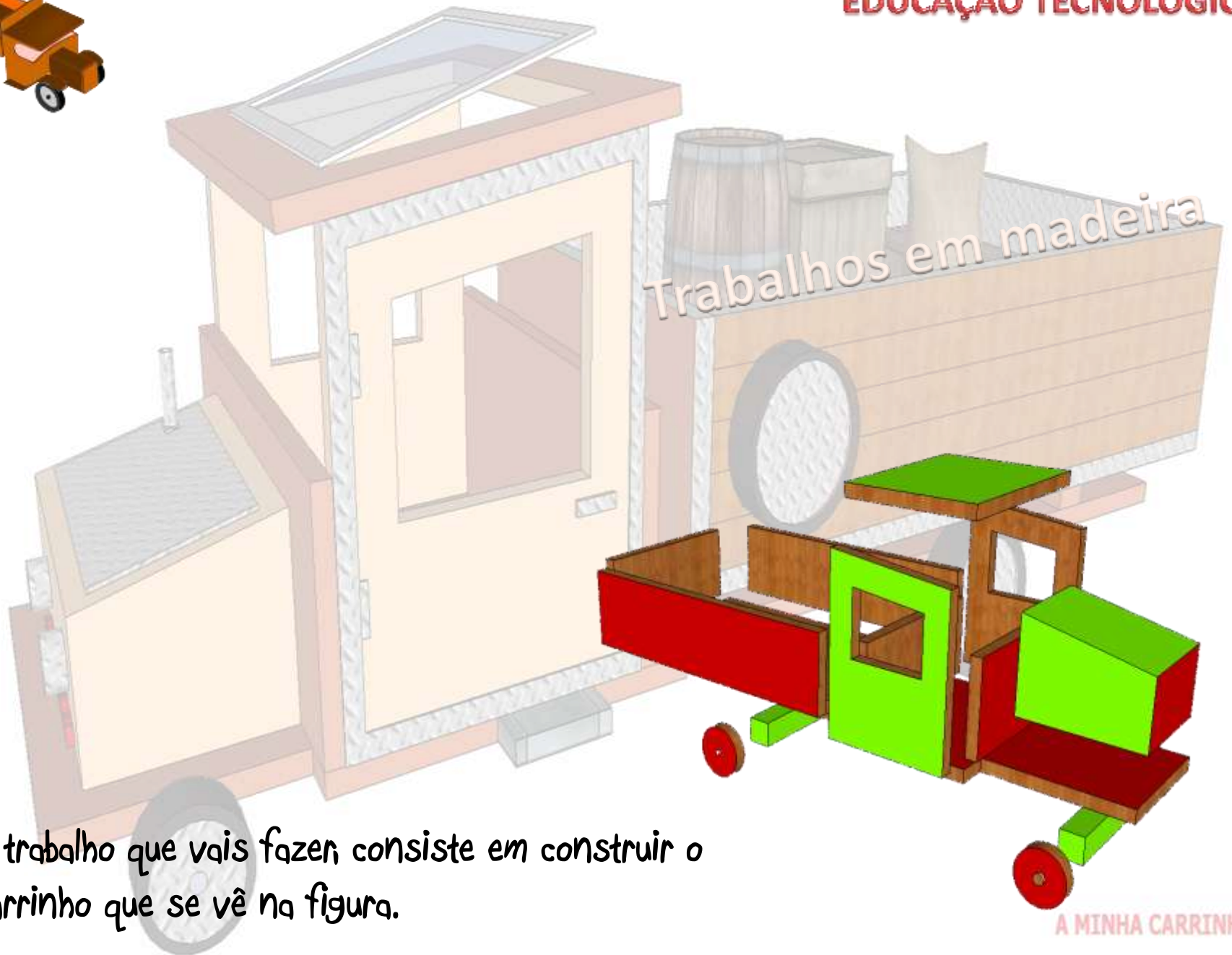

O trabalho que vais fazer consiste em construir o carrinho que se vê na figura.

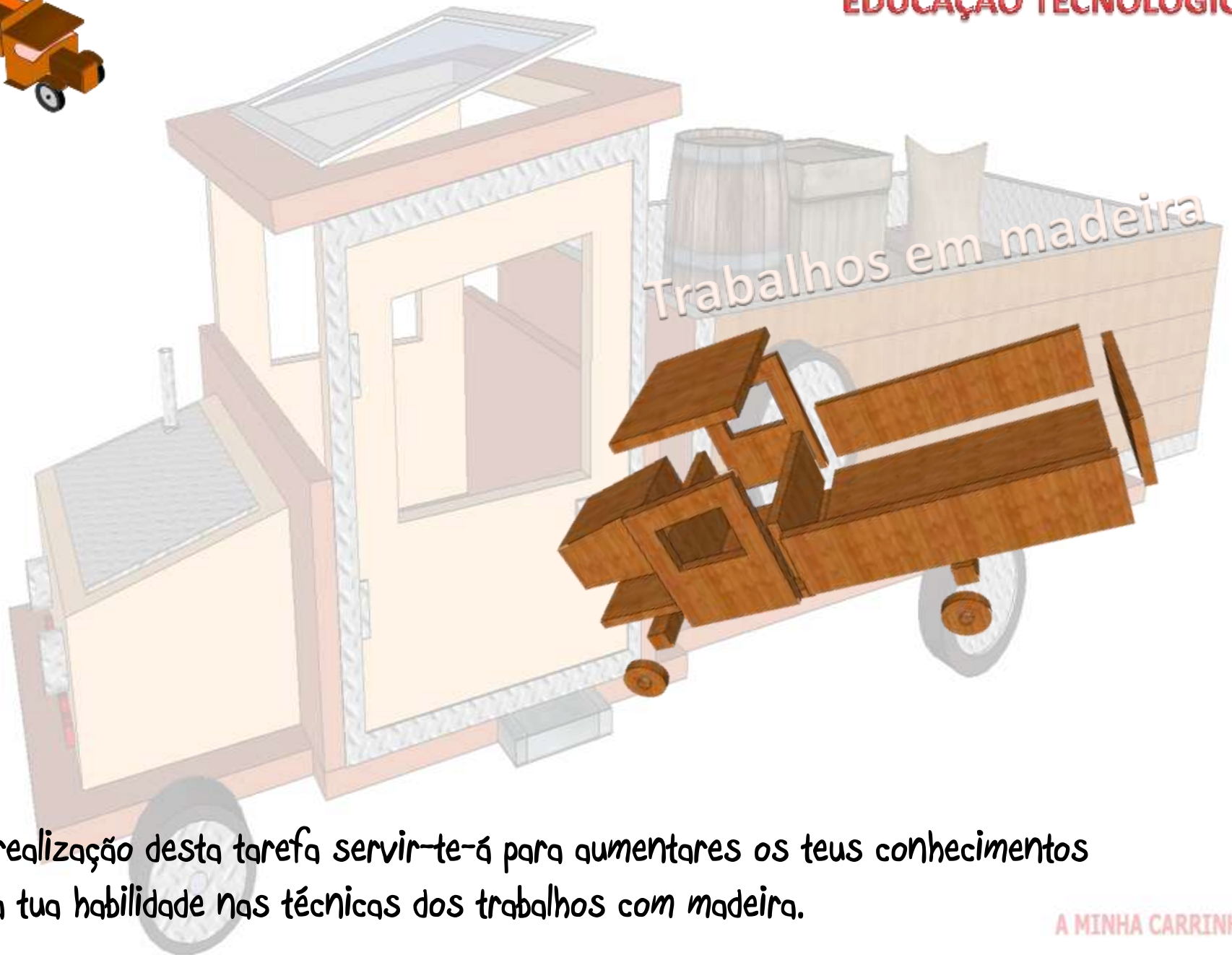

Trabalhos em madeira

A realização desta tarefa servir-te-á para aumentares os teus conhecimentos e a tua habilidade nas técnicas dos trabalhos com madeira.



Montagem do teu carrinho de madeira.

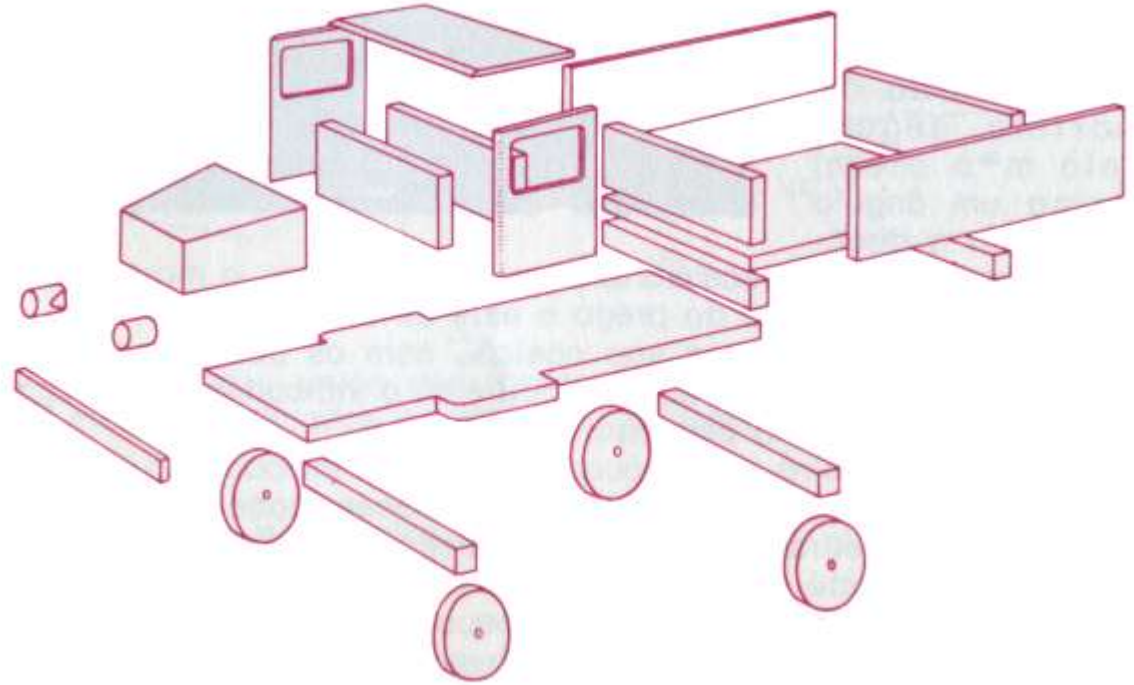

Quando tiveres todas as peças cortadas e lixadas, podes começar a montagem do carrinho unindo as peças umas às outras sucessivamente, por pregagem e colagem, nos seus lugares correspondentes, pela seguinte ordem:



Montagem do teu carrinho de madeira.

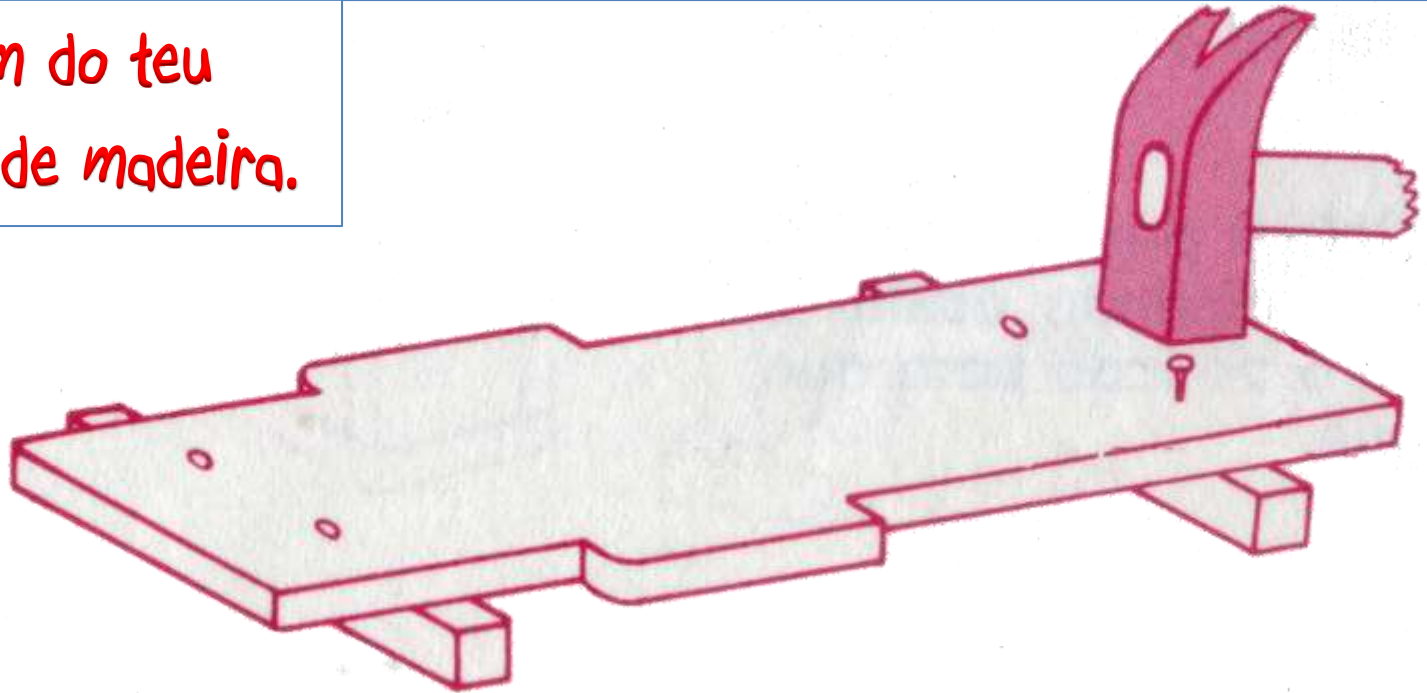

Cola e prega os eixos no quadro, passando os pregos através deles como vês na figura.





Montagem do teu carrinho de madeira.

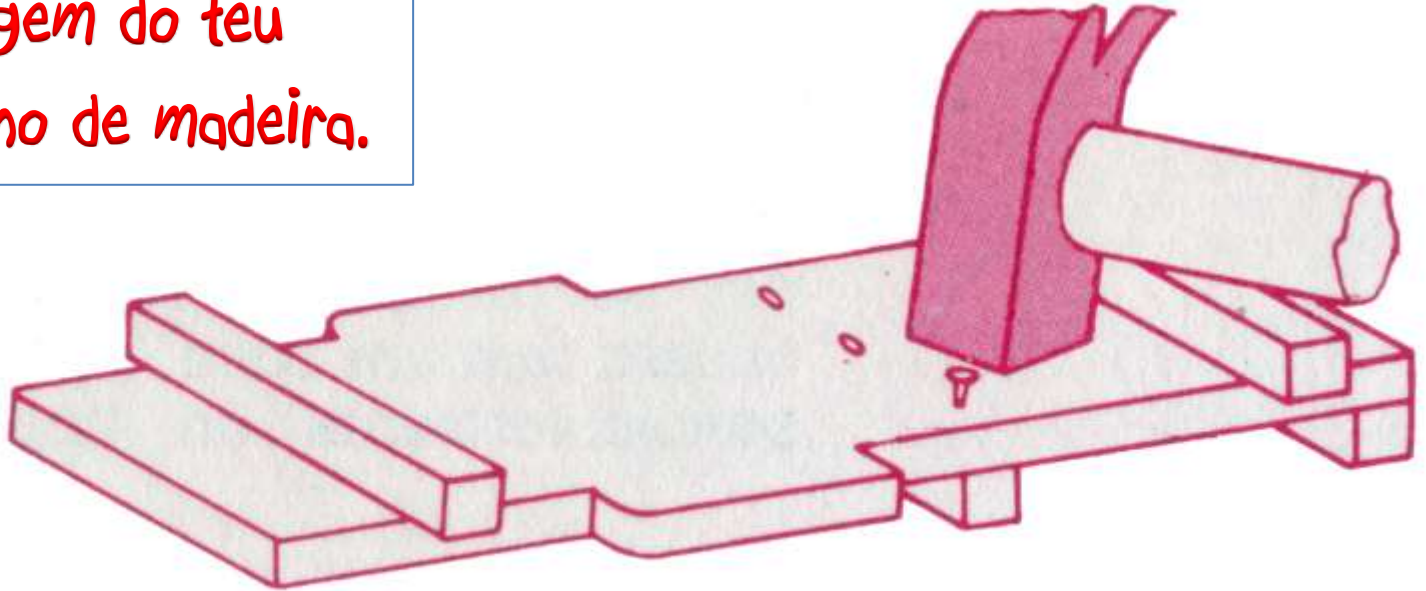

2

Cola e prega os suportes da caixa sobre o quadro, nas posições que se indica na figura.





Montagem do teu carrinho de madeira.

3

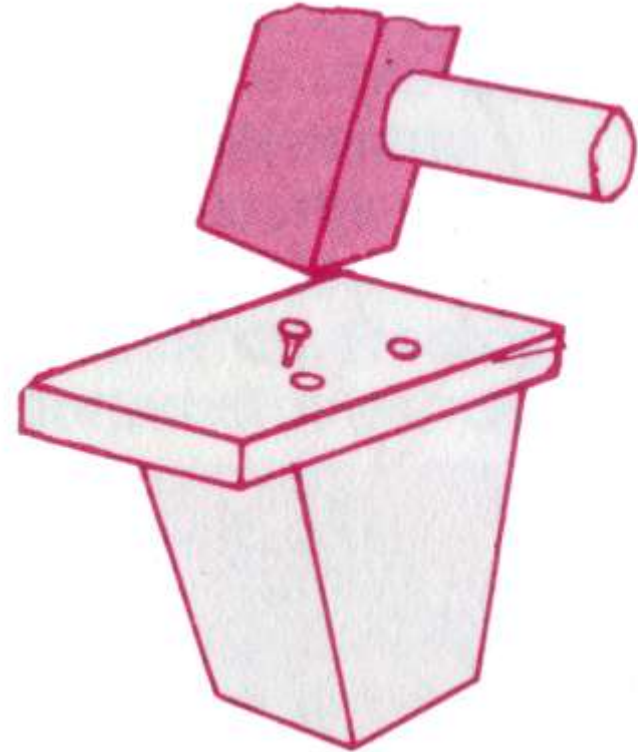

Cola e prega as peças como se mostra na figura. As duas peças devem ficar bem centradas uma na outra.





Montagem do teu carrinho de madeira.

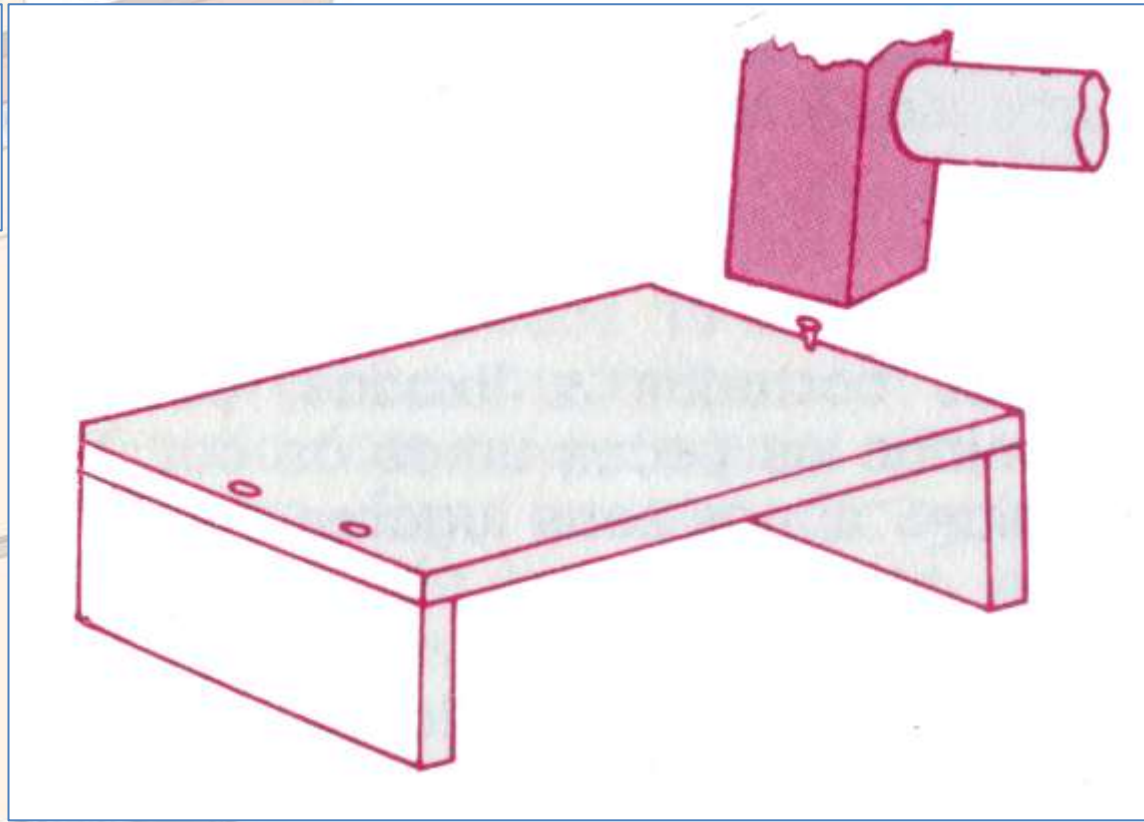

Cola e prega as peças da caixa, nas posições que se indica na figura.





Montagem do teu carrinho de madeira.

5

Cola e prega as peças da caixa, nas posições que se indica na figura.

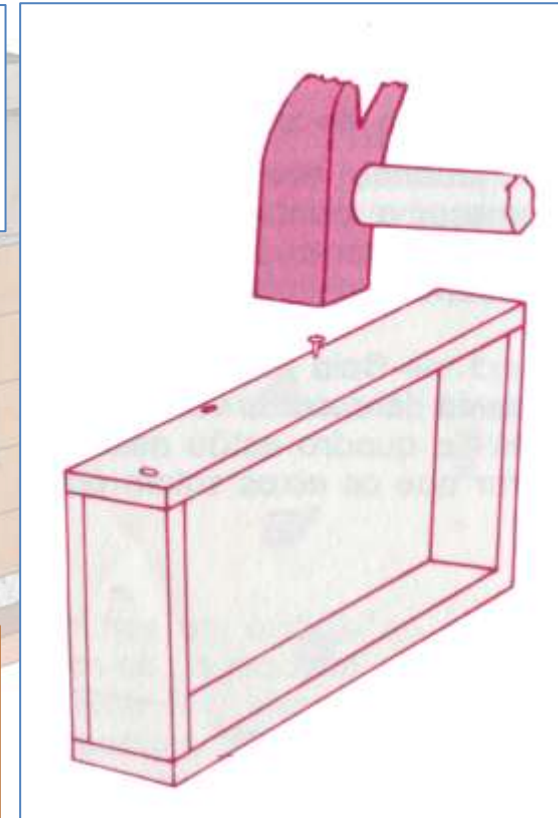



Montagem do teu carrinho de madeira.

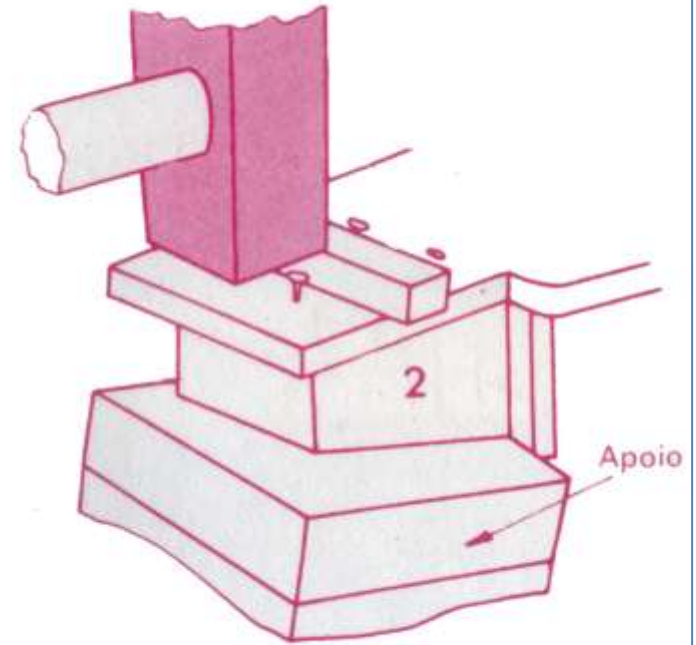

6

Cola e prega o conjunto de peças no quadro nas posições que se indica na figura.





Montagem do teu carrinho de madeira.

7

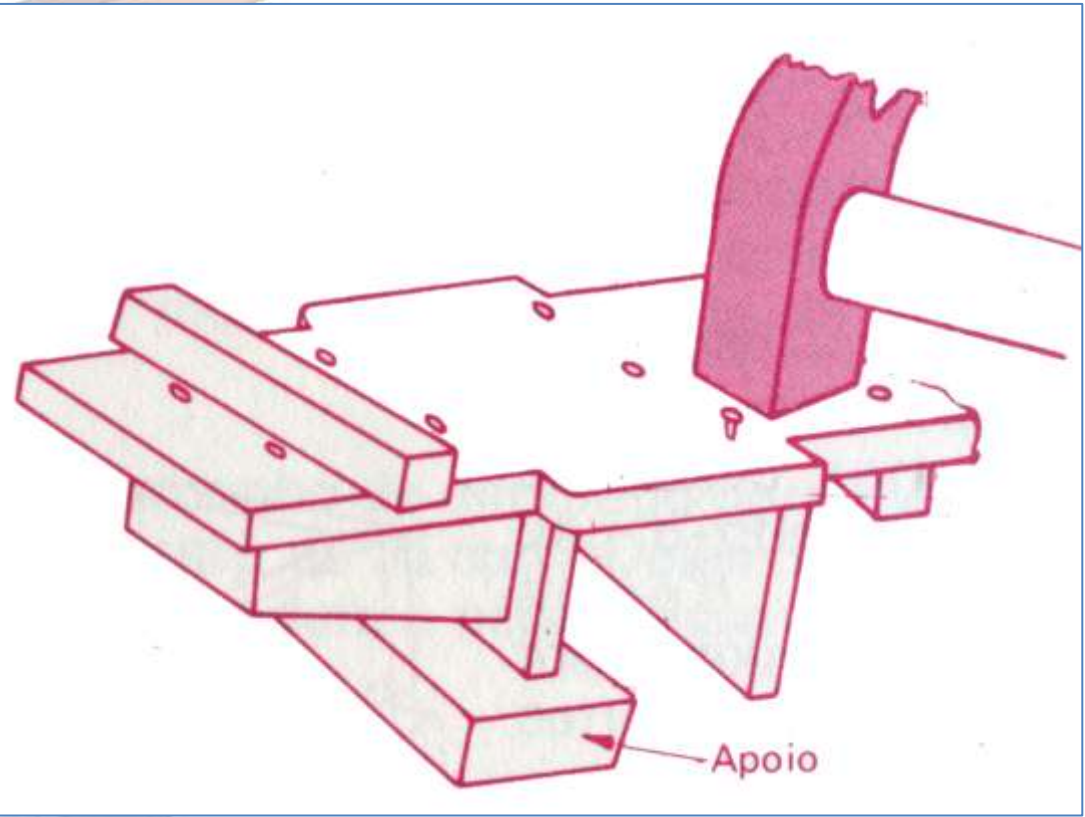

Cola e prega a peça no quadro nas posições que se indica na figura.





Montagem do teu carrinho de madeira.

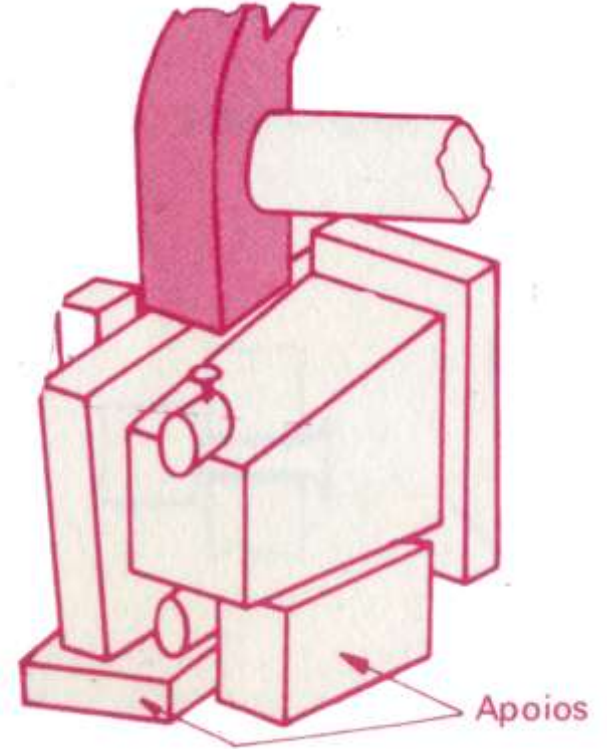

8

Cola e prega a peça no quadro nas posições que se indica na figura.





Montagem do teu carrinho de madeira.

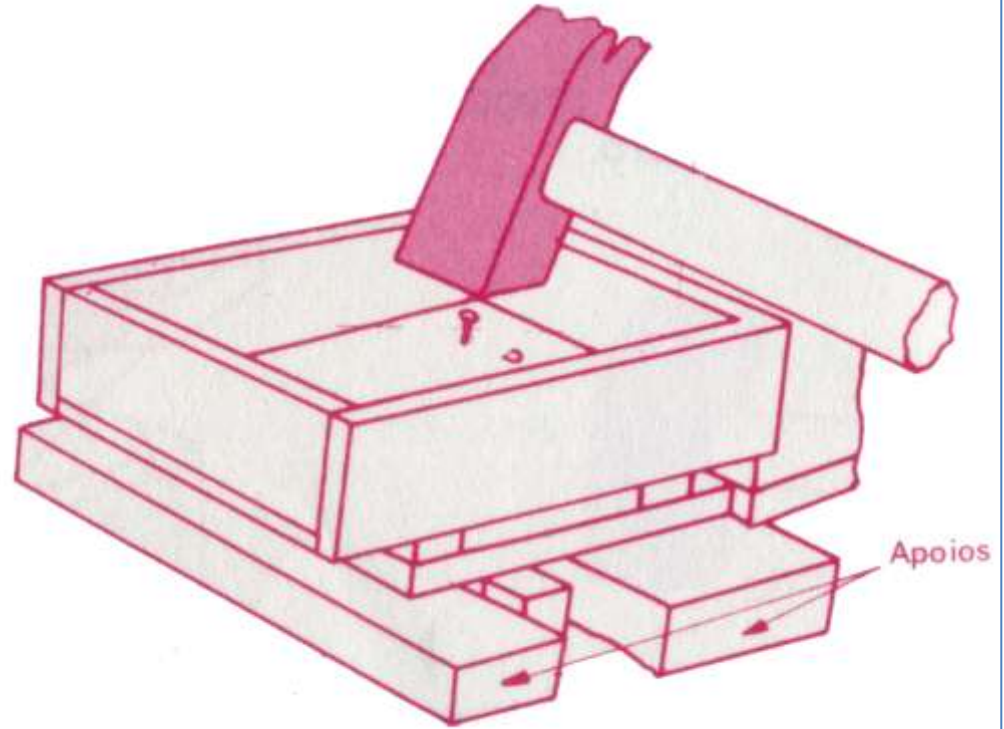

9

Monta a caixa sobre os seus suportes, colando-a e pregando-a, nas posições que se indica na figura.





Montagem do teu carrinho de madeira.

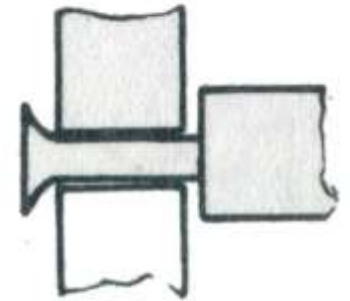
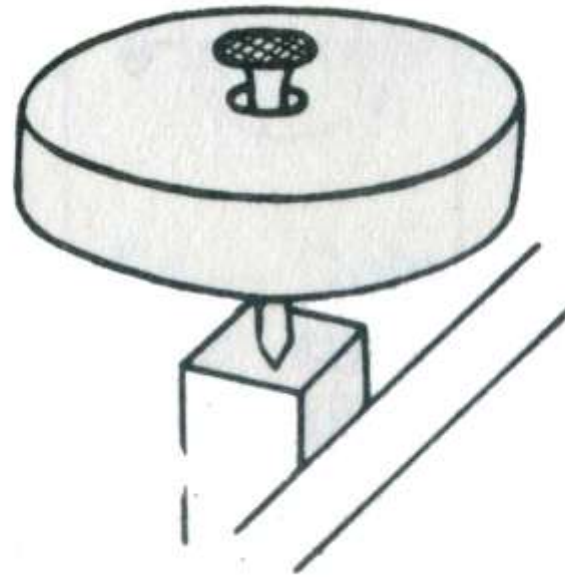

10

Instala as rodas nos eixos. Utiliza para isso quatro pequenos pregos mais grossos, nas posições que se indica na figura.



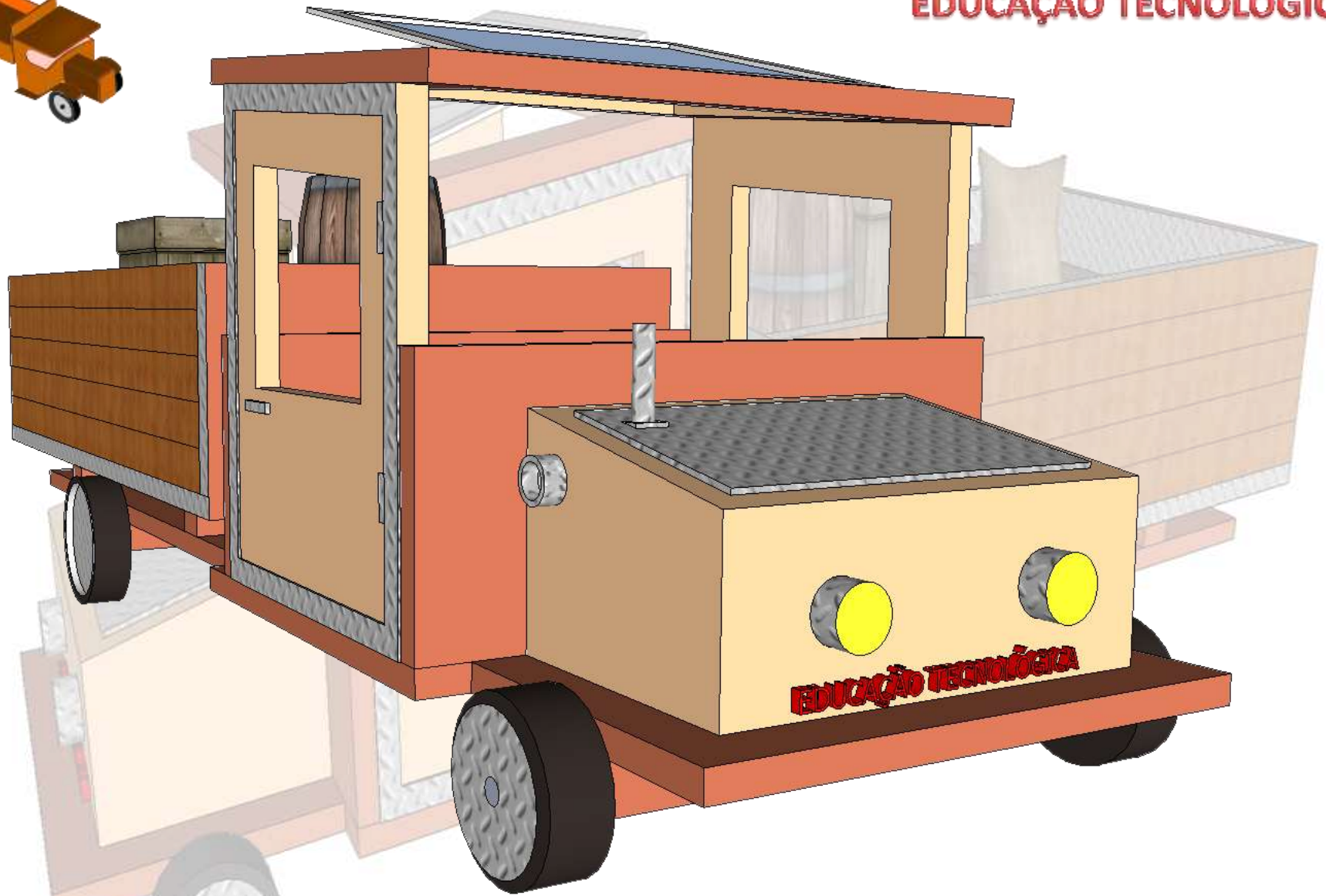

A realização desta unidade de trabalho servir-te-á para aumentares os teus conhecimentos e a tua habilidade nas técnicas dos trabalhos com madeira.